

One might almost say that the code is

Essential But Otherwise Unimportant - TMS 402/602 and the Practicing Engineer

TMS Annual Meeting
Denver, Colorado
October 13, 2022

John M. Hochwalt
john.hochwalt@kpff.com
Director of Engineering
KPFF Consulting Engineers



Abstract and Learning Objectives

Using TMS 402/602-22, the 2021 Haller Award Recipient will share his reflections on the relationship between the masonry building code, engineering practice, and successful projects. Why is the building code essential but otherwise unimportant? If the building code is unimportant, what concepts are important for practicing engineers to consider when designing masonry?

Learning Objectives:

1. What is the role of the building code in engineering practice?
2. What should the role of the building code be in engineering practice?
3. What makes a project successful? Does the building code help or hinder?
4. Other than code compliance, what should practicing engineers be considering in design?

Hardy Cross

*Most literature in the structural field deals with strength and stability for the very good reason, not always obvious to the amateur, that if a structure is not sufficiently strong, it makes little difference what other attributes it has. **One might almost say that its strength is essential and otherwise unimportant.***

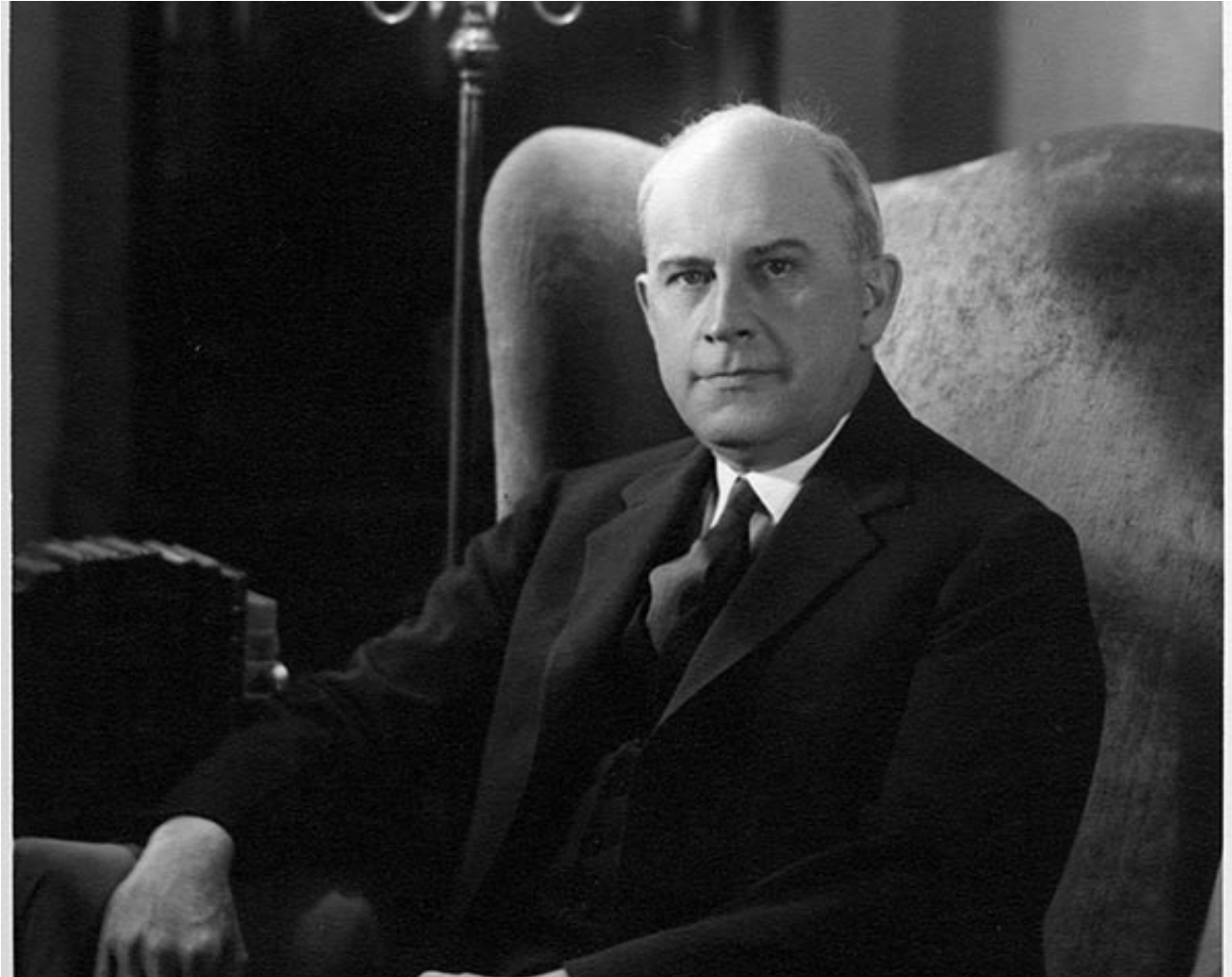

Outline of Presentation

Understanding and Envisioning:

- What is the role of TMS 402/602 in engineering practice?
- What should be the role of TMS 402/602 in engineering practice?

Practicing:

- What makes a project successful?
- What is (else) is important?

What is the Role of TMS 402/602 in Engineering Practice

An attempt to describe the current state of affairs

How Can We Describe The Role?

- Metaphorically
- Functionally

Metaphor 1

Holy Book

Characteristics

- Repository of wisdom
- Guides or rules for right living
- Infallibility
- Unchanging, eternal



Metaphor 1 Holy Book

How does the Code act like a holy book in practice?

- Sometimes treated as infallible
- We argue about interpretation
- We don't think it should change



Metaphor 2 Road Map

Characteristics

- Shows ways to get to your destination
- May not always be correct or up to date
- Doesn't show all the ways to get there

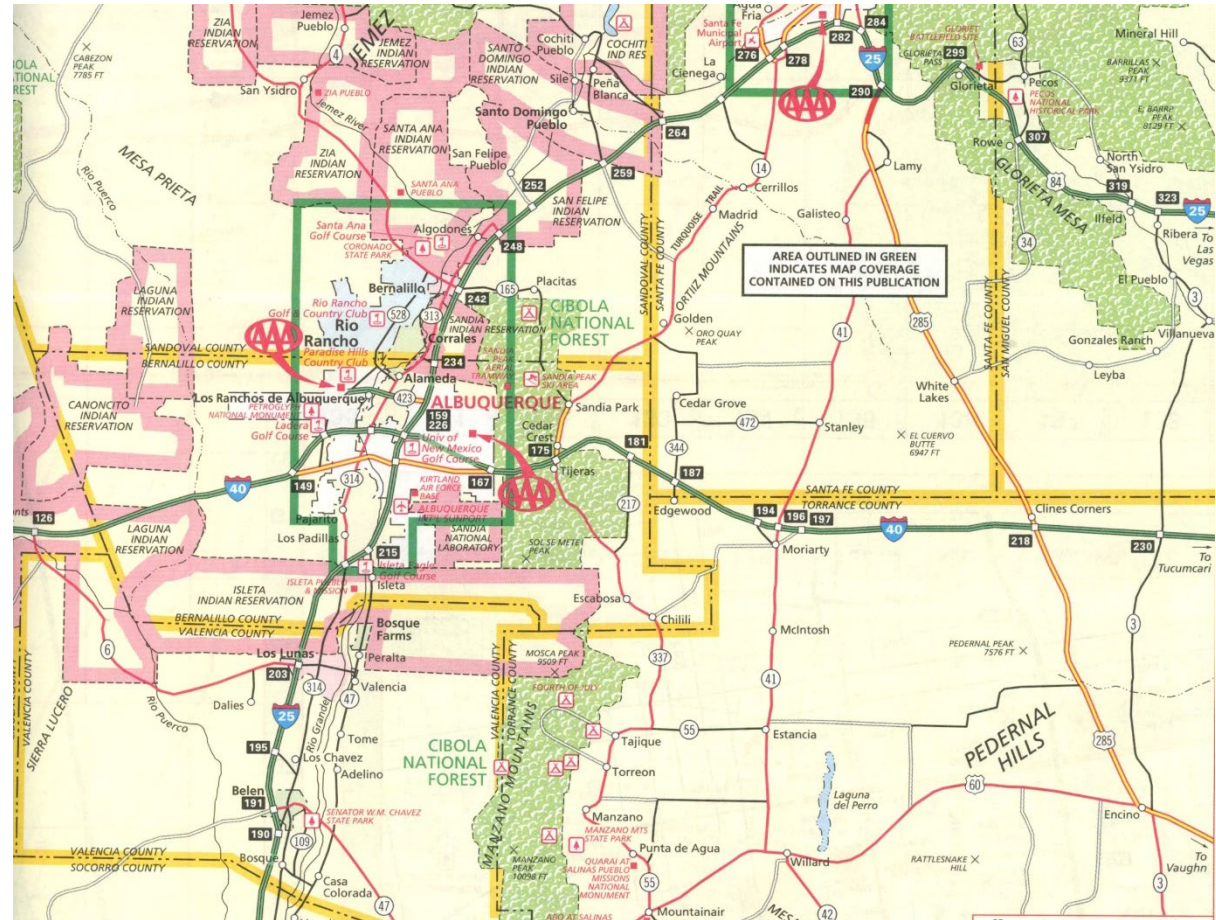

Metaphor 2 Road Map

How does the Code act like a road map in practice?

- Usually directs our design process
- Only consider paths shown on the map
- Engineering software = Google maps

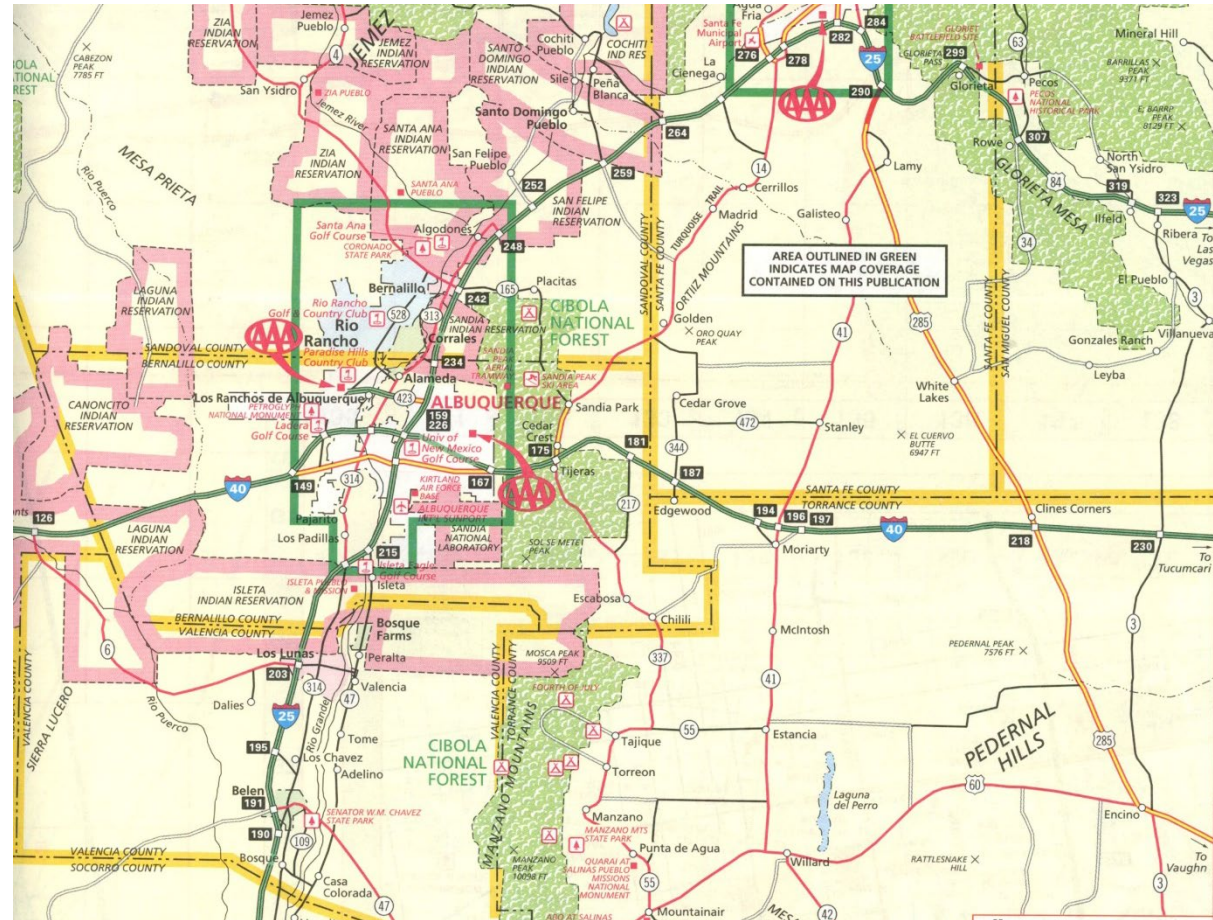

Metaphor 3 Guardrail

Characteristics

- Safety
- Direction
- Some Freedom

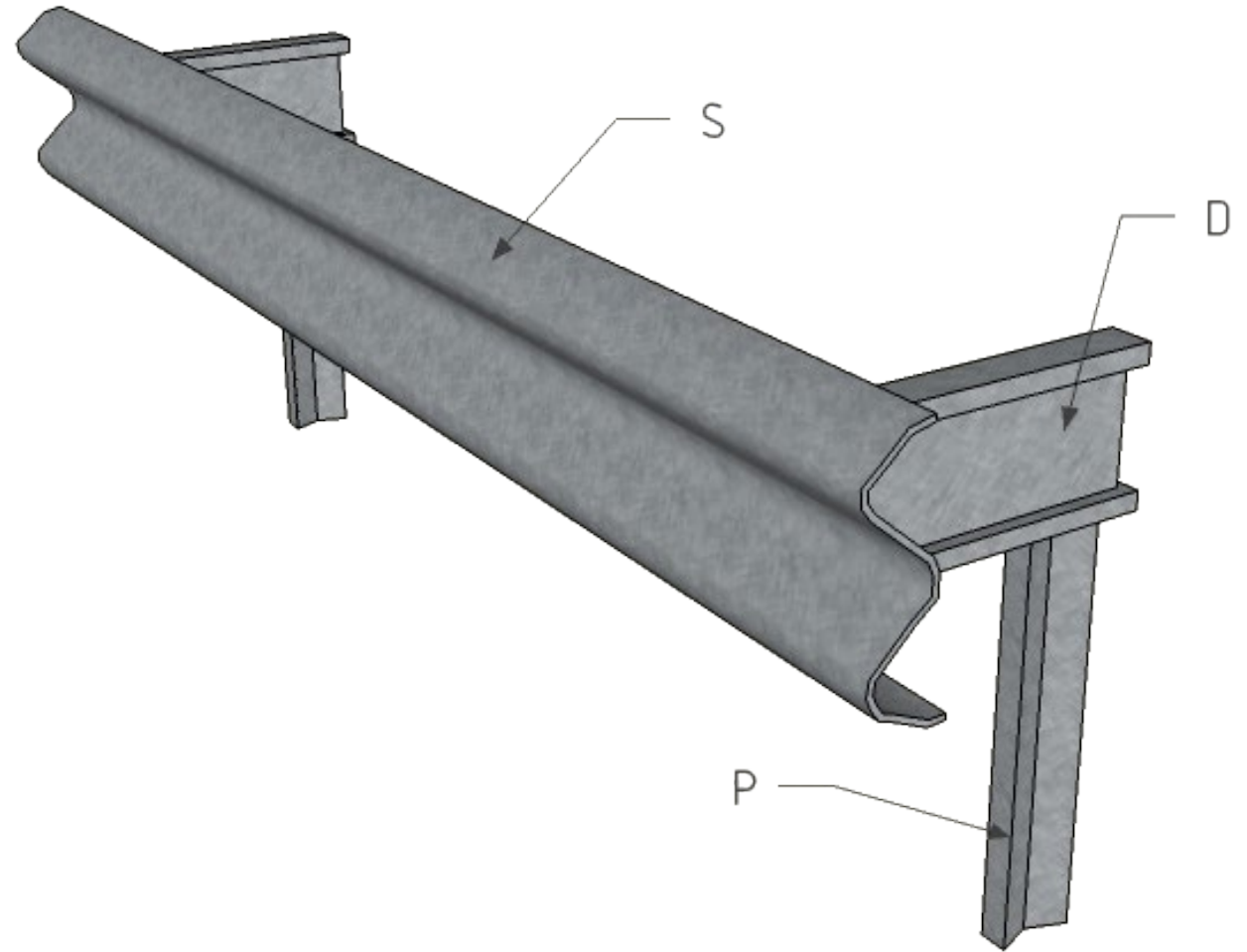

By Bauteile_Schutzplanke.png → Bauteile_Schutzplanke.jpg: Sascha Pöschl
(Mailtosap).derivative work: Saibo (Δ) - Bauteile_Schutzplanke.png, Public Domain,
<https://commons.wikimedia.org/w/index.php?curid=10631434>



By David Wilson from Oak Park, Illinois, USA - 20110327 41 CTA Green Line L @ 18th St., CC BY 2.0, <https://commons.wikimedia.org/w/index.php?curid=22021023>¹²



Seighean, Public domain, via Wikimedia Commons



By Nick Bramhall from Aberdeen, UK - Aberdeen Beach and Breakwater, CC BY-SA 2.0, <https://commons.wikimedia.org/w/index.php?curid=57478688>

Metaphor 3 Guardrail

How does the Code act like a guardrail in practice?

- Freedom versus Safety and Consistency
- What kind of guardrail is the Code?

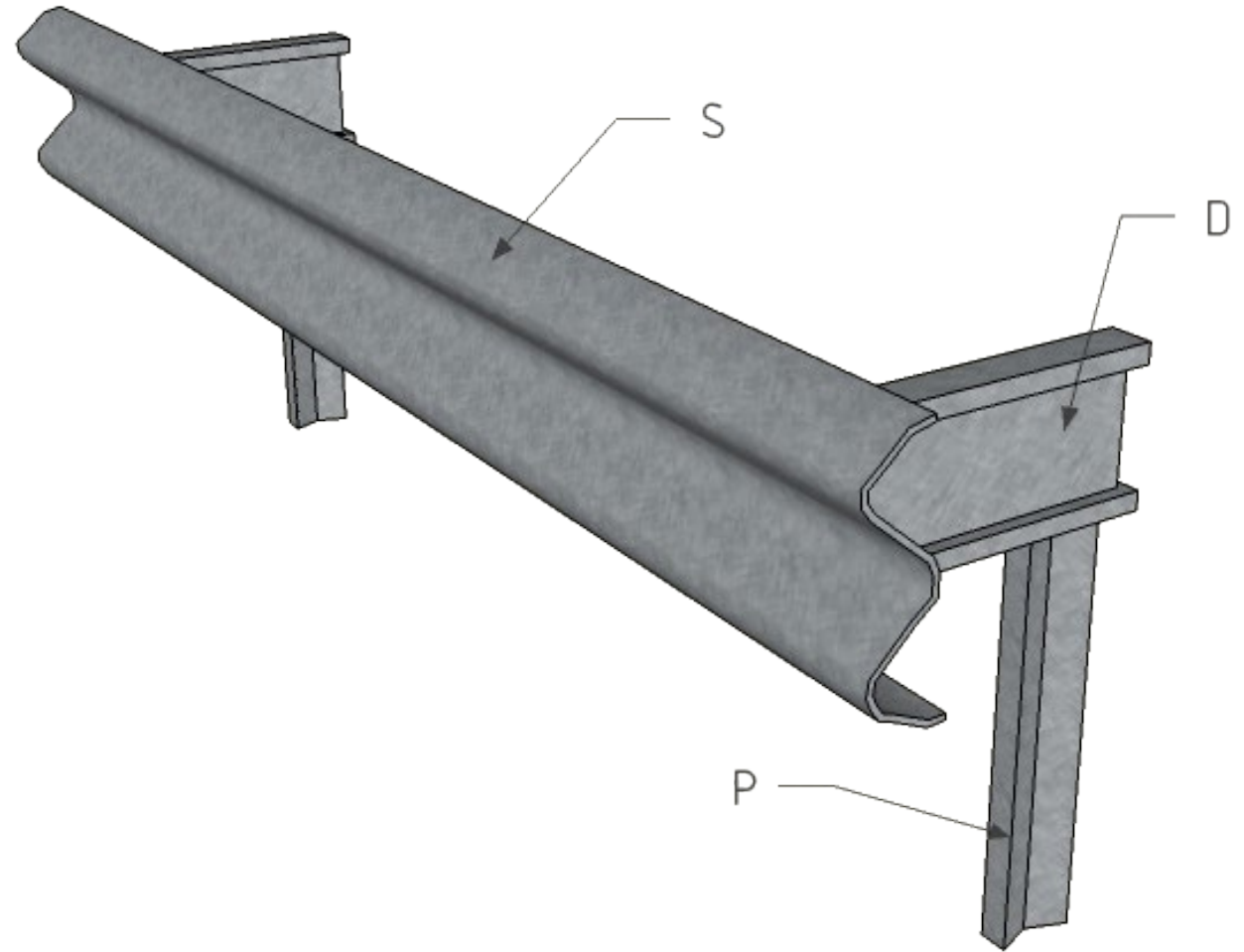

By Bauteile_Schutzplanke.png → Bauteile_Schutzplanke.jpg: Sascha Pöschl (Mailtosap).derivative work: Saibo (Δ) - Bauteile_Schutzplanke.png, Public Domain, <https://commons.wikimedia.org/w/index.php?curid=10631434>

Metaphor 4

Air We Breathe

Characteristics

- Life depends on it
- Pervasive
 - Taken granted
 - Hard to get perspective on

What is the role of the code?



Environment

- Pressure due to constraints
 - Fee
 - Resource
 - Schedule
- Other pressures – clients, contractors
 - Desire to please



Environment

- Regulatory
 - *Varies regionally*
 - *Varies by AHJ*
- Project Types
 - *Partition walls*



Functional

Legal Document

- Risk of non-compliance
 - Authority Having Jurisdiction
 - Claims
- Protection if compliant?



Functional

Practical

- Starting point of design is code compliance
- Design tools created based on provisions
- Typical details developed for compliance with prescriptive provisions
- Contractor alternates, field issues judged for compliance

Functional

Labor Saving Device

- Repository of shared knowledge:
 - Past
 - Present
 - Future
- Crutch
 - Lazy thinking
 - Something to blame



Functional

Source of Frustration

- Change
- Complication
- Confusion
- Constraint



What Should be the Role of TMS 402/602 in Engineering Practice?

An attempt to articulate a vision for the future

Hardy Cross

Engineering is essentially a craft. It is the glory of engineers that they are craftsmen, that they are artists, and while as good craftsmen they follow a systematic and orderly procedure, they are highly resistant and antagonistic toward over regimentation. They demand freedom of their art, freedom to recreate, to rearrange.

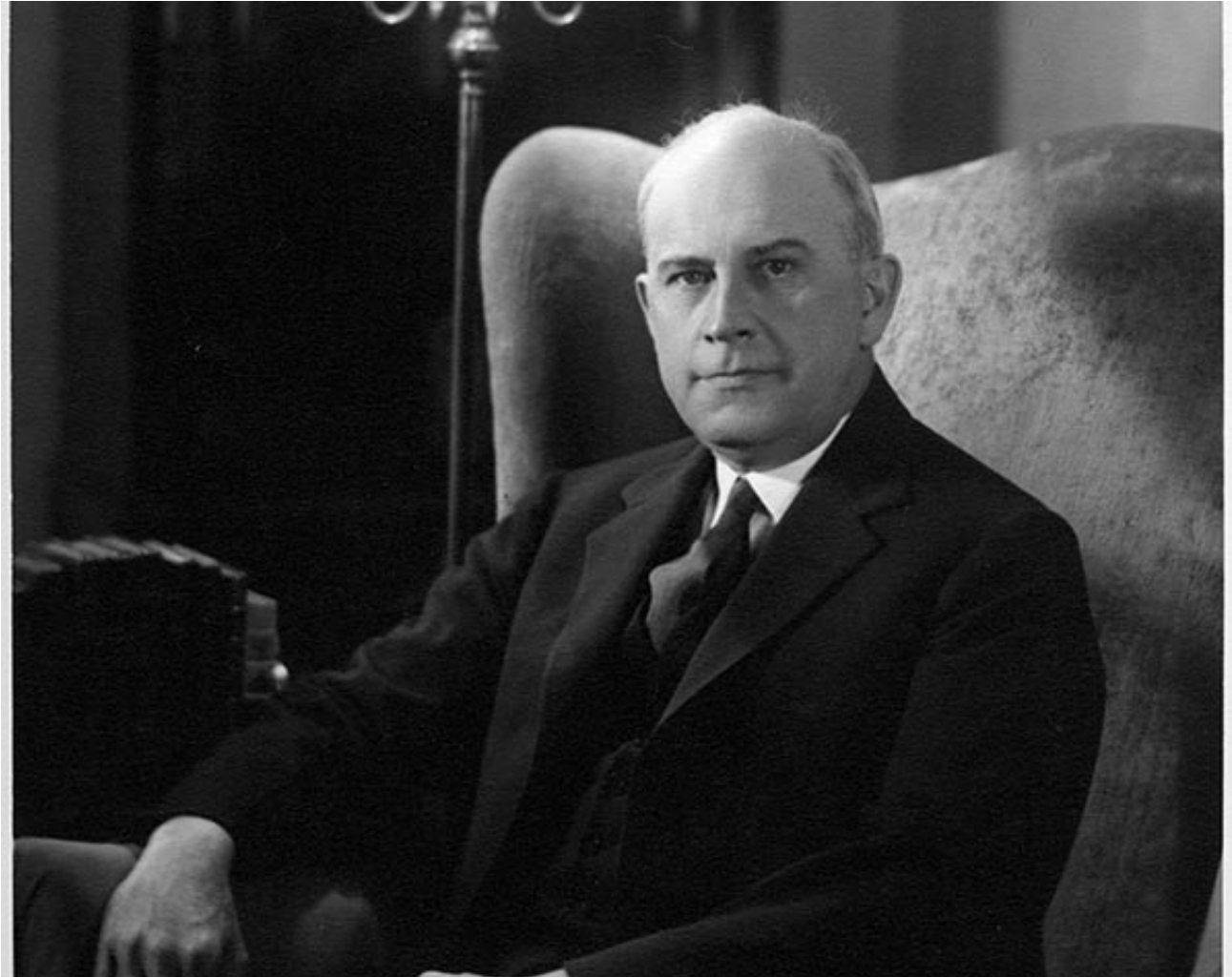

Desired Function

- Adaptable
 - Quick Solutions
 - Innovation
 - Simple Systems
 - Complex Systems

7.3.1 Nonparticipating Elements

Masonry elements that are not part of the seismic-force-resisting system shall be classified as nonparticipating elements and shall be isolated in their own plane from the seismic-force-resisting system. Isolation joints and connectors shall be designed to accommodate the design story drift.

Exception: Isolation is not required if a deformation compatibility analysis demonstrates that the nonparticipating element can accommodate the inelastic story drift, Δ , of the structure in a manner complying with the requirements of this Code. Elements supporting gravity loads in addition their self-weight shall be evaluated for gravity load combinations of $(1.2D + 1.0L + 0.15S)$ or $0.9D$, whichever is critical, acting simultaneously with the inelastic displacement and shall have a ductility compatible with the ductility of the seismic-force-resisting system. The influence of any non-isolated nonparticipating elements on the seismic-force-resisting system shall be considered in design in accordance with Section 4.1.6 of this Code.

Desired Function

- Repository of Knowledge
 - Commentary
 - Expanded Commentary
 - Design Aids

(a) Figure CC-9.3-3 shows that when the neutral axis depth c exceeds the critical neutral axis depth c_{cr} , the extreme compression fiber strain in the masonry reaches a value ϵ_{mm} in excess of the maximum usable strain ϵ_{mu} . The corresponding ultimate curvature ϕ is ϵ_{mu} / c . Based on the model of Figure CC-9.3-2(b), with $\ell_p = \ell_w/2$ and assuming the wall experiences the Risk-Targeted Maximum Considered Earthquake (MCE_R) event:

$$\delta_{MCE} = \theta_p h_w = (\phi_u \ell_p) h_w = \left(\frac{\epsilon_{mm}}{c} \frac{\ell_w}{2} \right) h_w \quad (\text{Equation 3})$$

From Equation 3:

$$\epsilon_{mm} = 2 \left(\frac{\delta_{MCE}}{h_w} \right) \left(\frac{c}{\ell_w} \right) \quad (\text{Equation 4})$$

Desired Function

- Collaborative rather than Adversarial
 - Transparency
 - Receptive to outside ideas

2022 TMS 402/602 Committee Response to Public Comment

Committee: Seismic & Limit Design Subcommittee	Ballot #: 19
Item #: 19-SL-13	
Technical Contact/Email: Alan Robinson / arobinson@trseinc.com	
Public Comment Number: 2022 Comment # 120	
Public Comment Response Based on TMS 402/602 Draft Dated 6/1/2021	
This ballot item proposes the following response to the Public Comment:	
<input checked="" type="checkbox"/> <i>Committee agrees with Public Comment, change is proposed</i>	
<input type="checkbox"/> <i>Committee agrees comment has merit but proposed changes are not completely consistent with Public Comment</i>	
<input type="checkbox"/> <i>Committee disagrees with Public Comment and no changes are proposed</i>	
<input type="checkbox"/> <i>Committee unable to fully develop a response to Public Comment</i>	
<input type="checkbox"/> <i>Public Comment only requires a response, no change to document</i>	

Desired Function

- Engineering first, then code
 - ~~What does the code allow?~~
 - What is the right engineering solution?

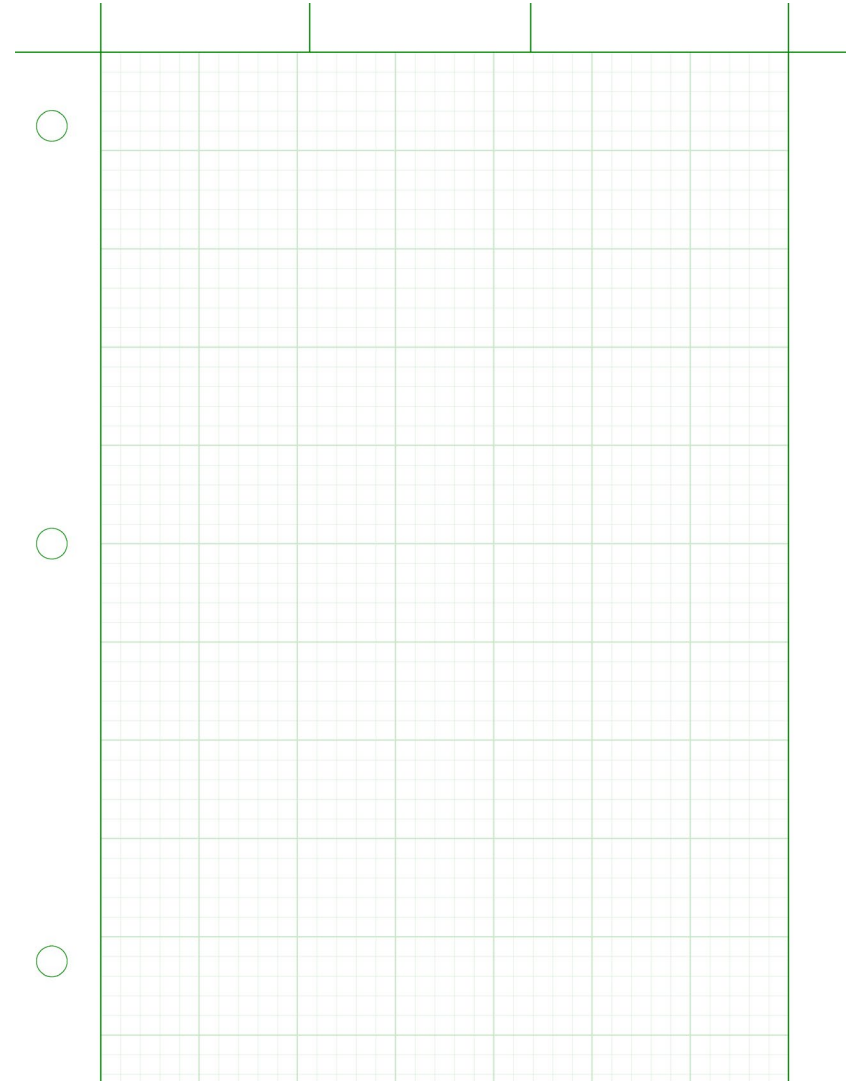

Hardy Cross

Various sources aid the engineer in determining strength. No one of them is more important than another. Analyses, tests, experience and such intuitive common sense as may be personally developed about structural stability; these are all helpful, but they can also be dangerously misleading. Evidence from the four sources rarely agrees completely. Great engineers are those who can weigh this evidence and arrive at a reasonable answer through judgment as to its dependability.



What Makes A Project Successful?

An attempt to state the obvious

Table Stakes

- Engineering
 - Functional
 - **Safe = Code Compliant**
- Service
 - Responsive
 - Timely
 - No surprises
 - Expectations met



Ab5602, Public domain, via Wikimedia Commons

Table Stakes

- Business
 - Profitable (all parties)
 - Limit iteration
 - Constructible
 - Risks Mitigated
 - Future Opportunities
 - No call backs



Ab5602, Public domain, via Wikimedia Commons

Winning Hand

- Engineering
 - Elegant
 - **Innovative**
- Service
 - Enjoyable



Cornischong at Luxembourgish Wikipedia, CC BY-SA 1.0
<<https://creativecommons.org/licenses/by-sa/1.0>>, via Wikimedia Commons

What Else is Important?

An attempt to think beyond strength and safety

Hardy Cross

*Most literature in the structural field deals with strength and stability for the very good reason, not always obvious to the amateur, that if a structure is not sufficiently strong, it makes little difference what other attributes it has. **One might almost say that its strength is essential and otherwise unimportant.***

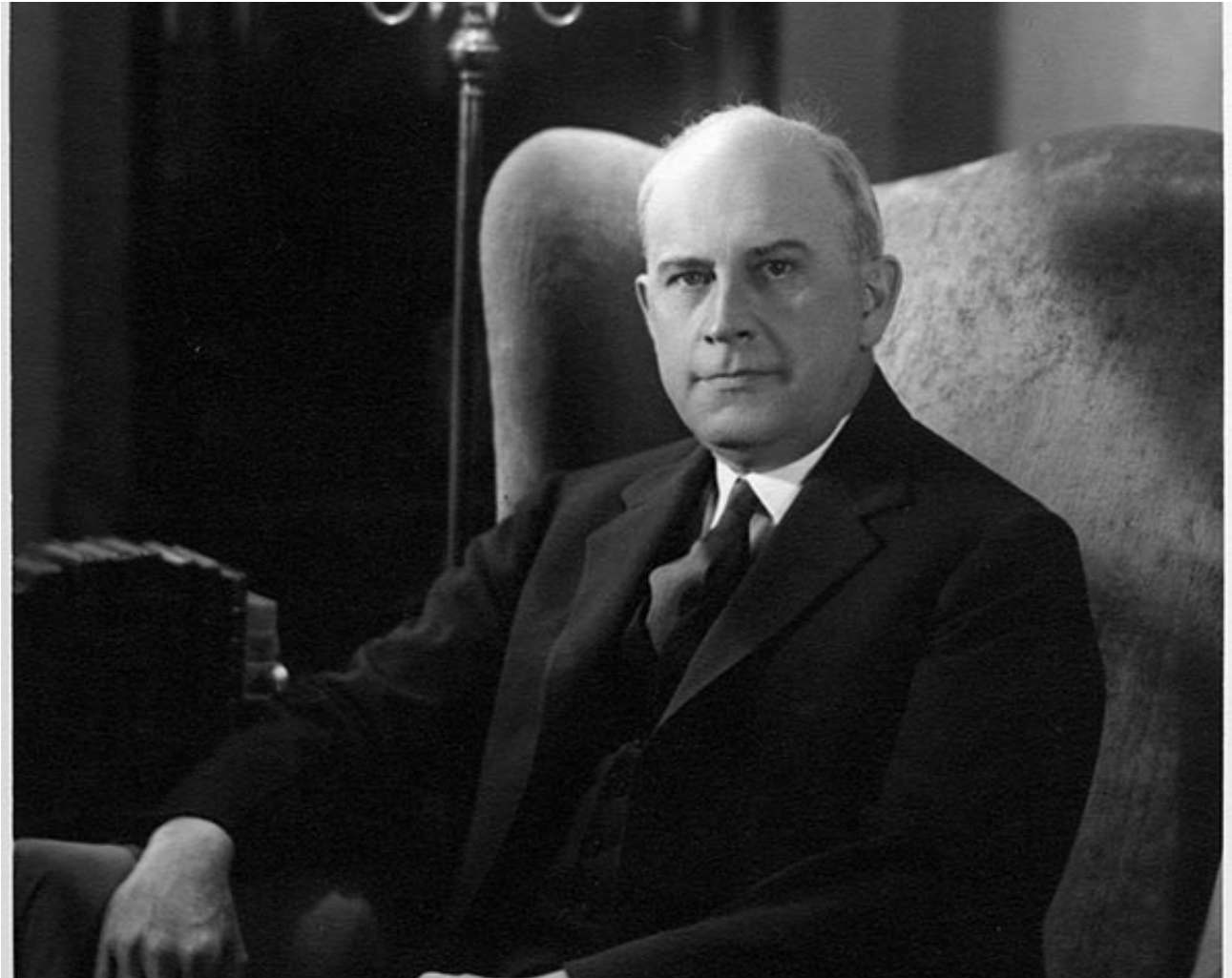

Hardy Cross

*Yes, there is development and progress. In some fields the development is slow. Men must learn to think more clearly in space and be less restricted to two-dimensional design. **They must pay more attention to movements and vibrations.** They need much more information on the properties of materials. **Probably they need to reappraise seriously the importance of durability.** A few need to be told that the pursuit of novelty does not always lead to progress.*

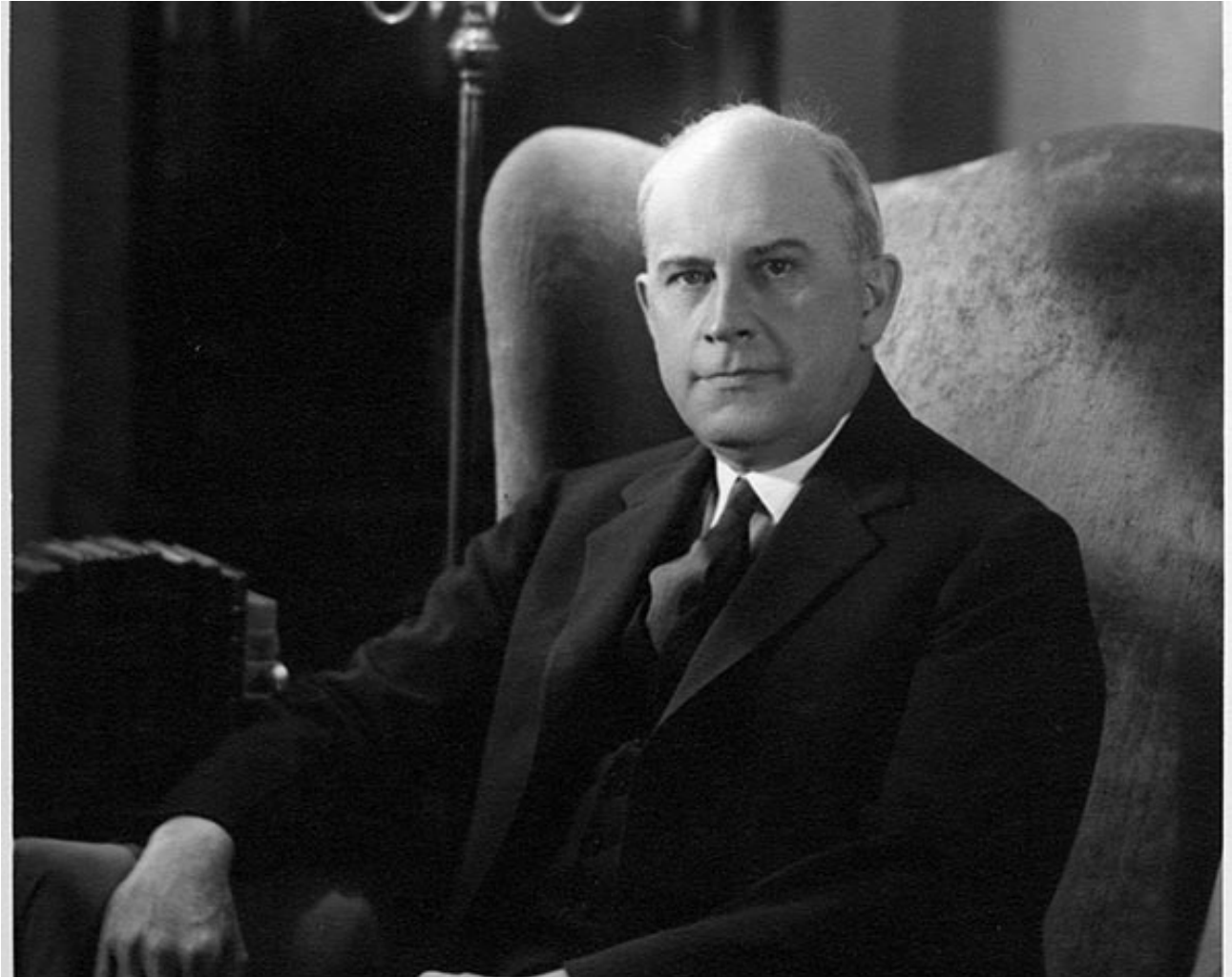

What (else) is Important?

Serviceability

- Movements and Vibrations
 - Accommodation of environmental movements
 - Crack control
- Moisture Control



What (else) is Important?

Service Life

- Durability
- Maintainability
- Energy Performance
- Resiliency



What (else) is Important?

Responsiveness

- Sustainability
- Elegance
 - **Respect for material**

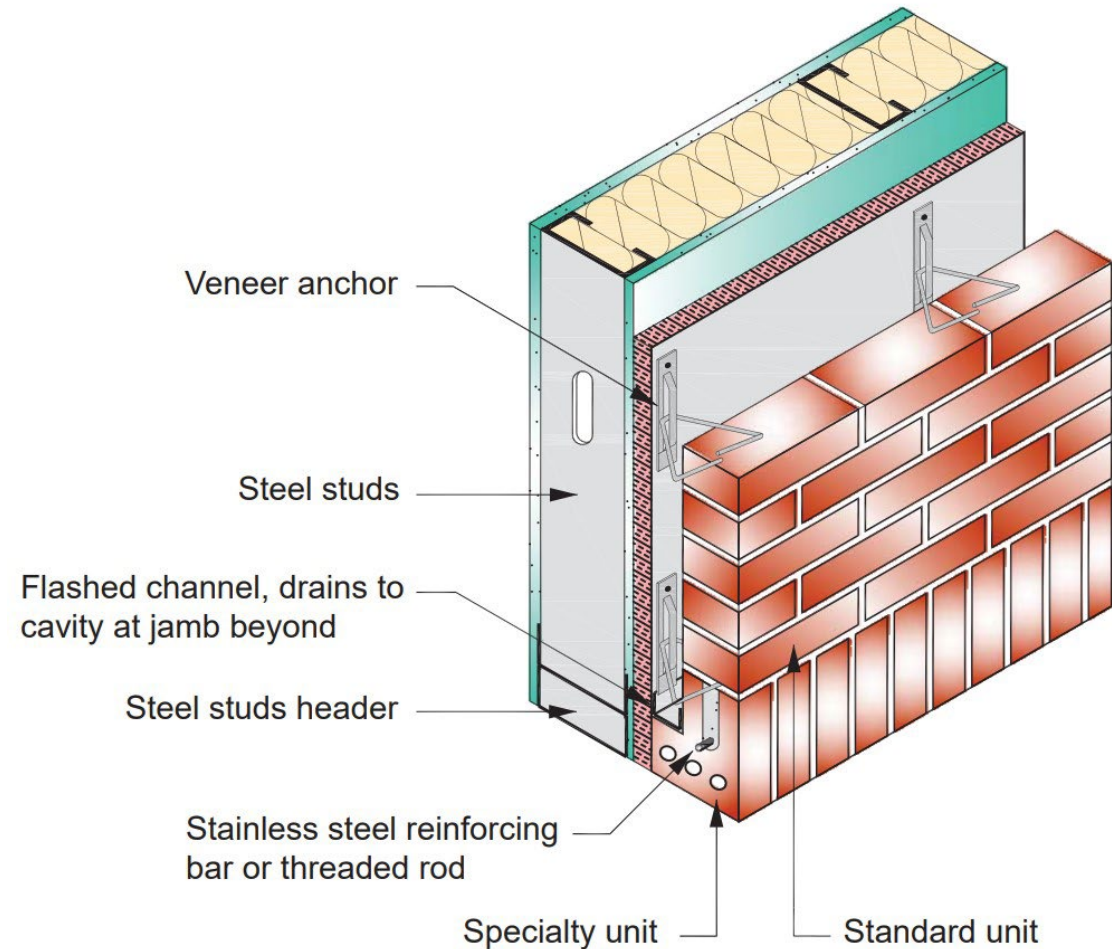

Conclusion

John M. Hochwalt

john.hochwalt@kpff.com

Director of Engineering

KPFF Consulting Engineers

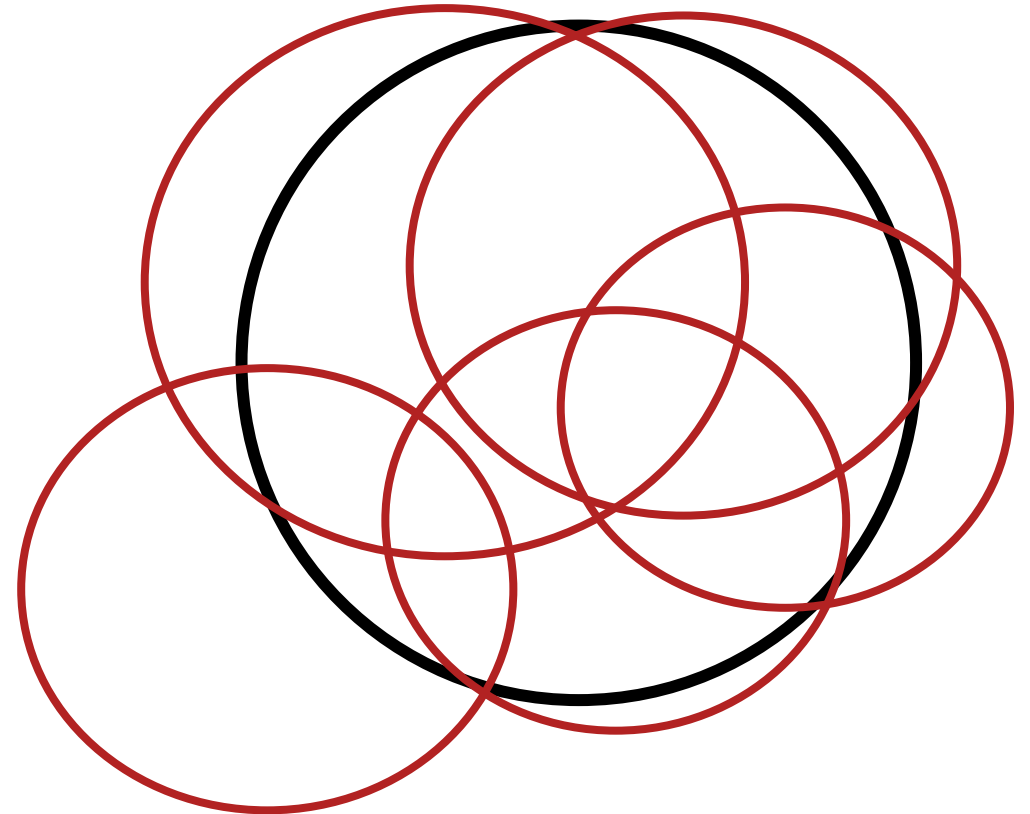

Bonus Content

Some further items for your consideration after the presentation.

Ron Swanson

Fictional character from *Parks and Recreation*:

Ron: I understand that city codes exist. And I know why they exist. And I understand that you enforce them.

Mark: OK.

Ron: OK, good talk. Can you sign off on my plans now?

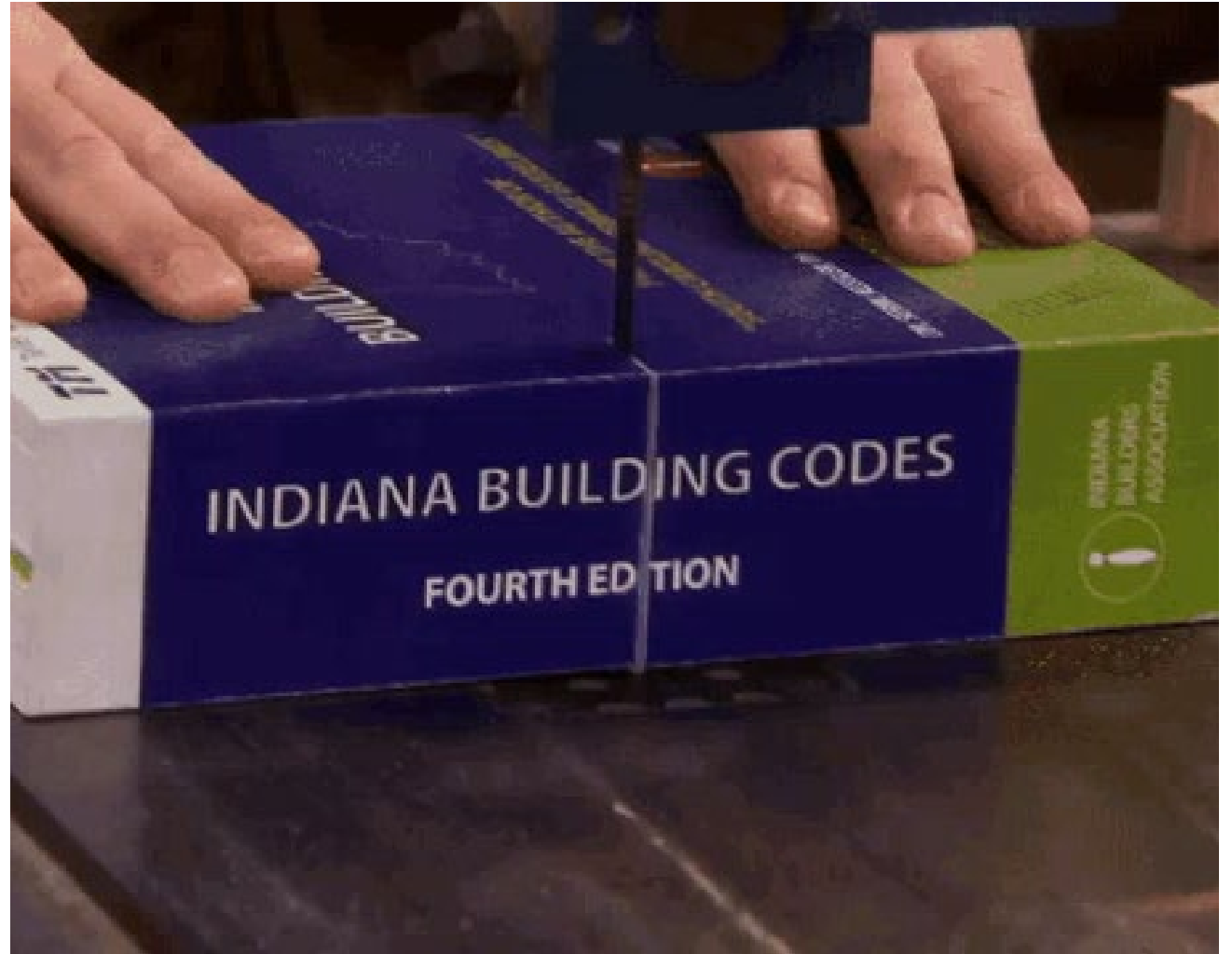

<https://tenor.com/view/ron-swanson-workshop-ron-swanson-cut-book-gif-17199981>

Ron Swanson

Fictional character from *Parks and Recreation*:

Mark: Ron, none of this is up to code.

Ron: Sure it is. It's up to the Swanson code.

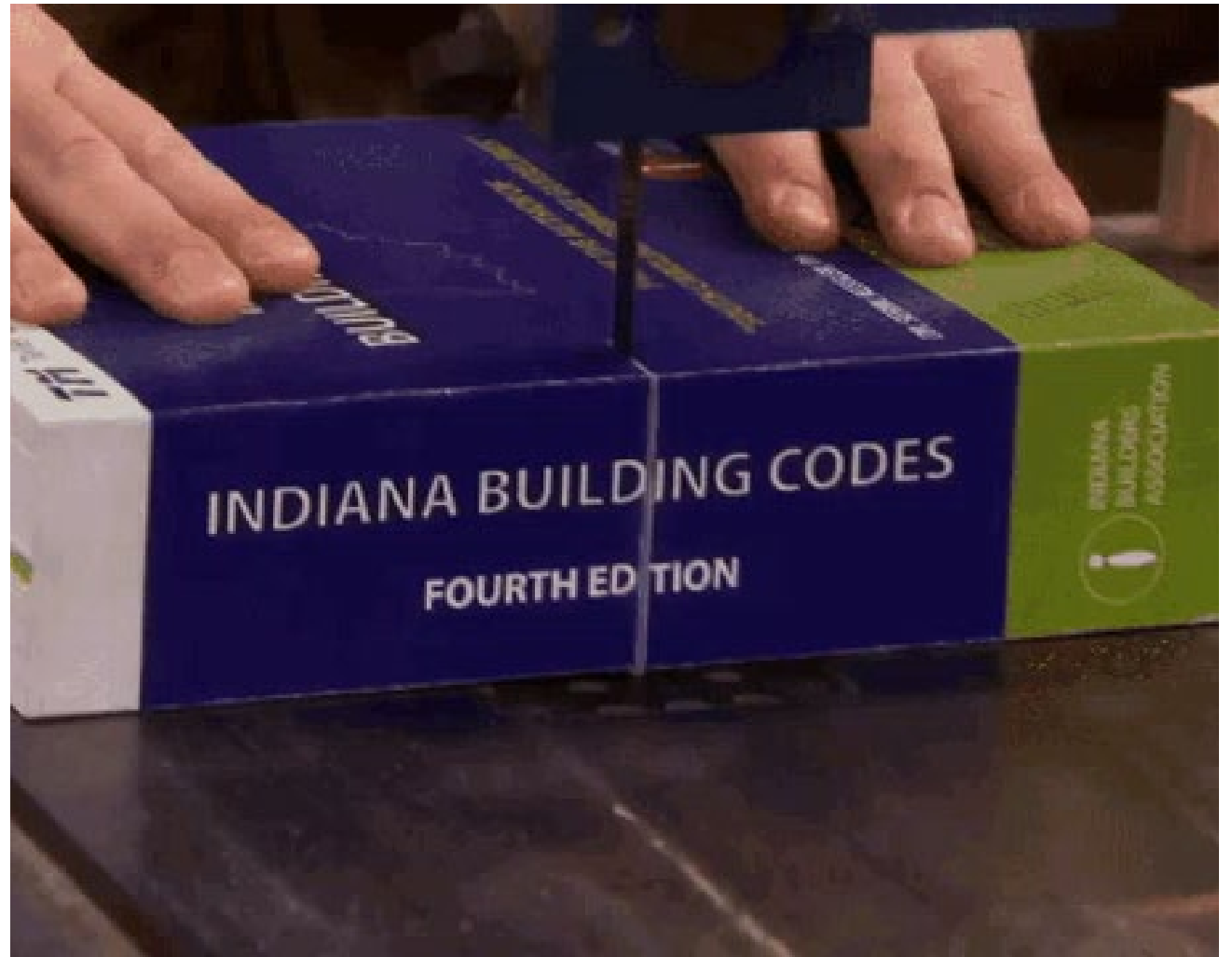

<https://tenor.com/view/ron-swanson-workshop-ron-swanson-cut-book-gif-17199981>

Hardy Cross

But there is another purpose of standardization here and in most engineering fields. It is helpful to think about engineering by distinguishing its creative and its routine features. . .

It had the advantage that these young men could follow the standards and arrive at the same result whether they lived in Boston or Los Angeles and whatever the condition of their health or temper at the time they made the computations. In other words, work could be checked . . .

The important point here is that some types of planning, designing and experimenting can be put on an assembly line and some types can be put on an assembly line of skilled brains only, but much of the most important work cannot be done by using fixed rules, standardized formulas or rigid methods.

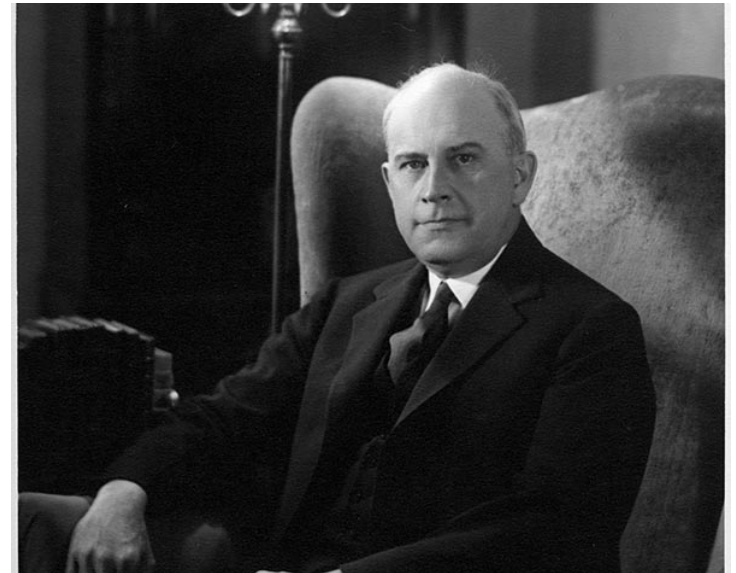

Hardy Cross

In the field of structural design the effort to get intelligence through standardization has been carried pretty far. In reinforced concrete, for example, it has been necessary to set up elaborate standards. Out of this work came a narrowly circumscribed standardization of procedures, which is called "the theory of reinforced concrete" and to which unfortunate students are exposed. Few will question that the standardized theory of reinforced concrete is perhaps as complicated a bit of nonsense as has been conceived by the human mind. It does, however, work pretty well as a check on indiscriminating unintelligence.

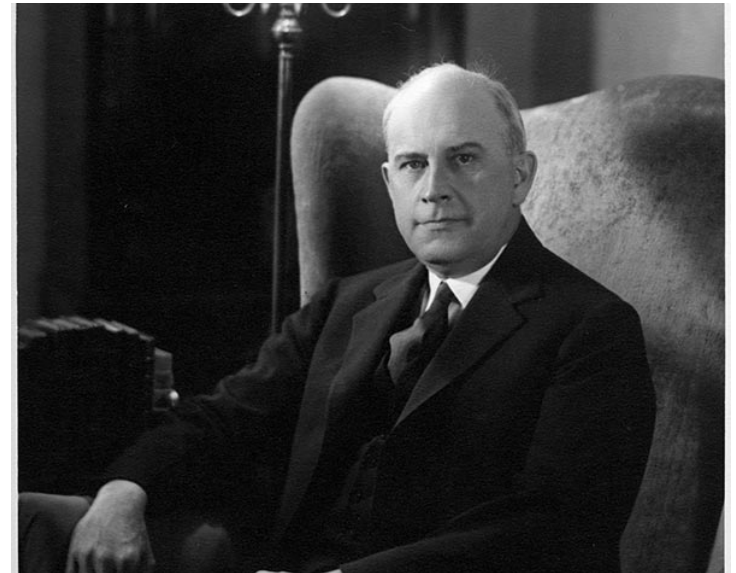

Hardy Cross

Development and advancement are largely dependent upon research which, by necessity, deals with controlled study of small isolated details.

There is usually a long period before such details can be assembled into generalization. Many try to seize upon these details before they have been digested and apply them at once. What are supposed to be results of investigations are often incorporated in specifications and codes before the investigation itself has been completed, much less digested. There is, then, always the danger that immature conclusion will become "frozen" in practice and hence be reported as a "new development."

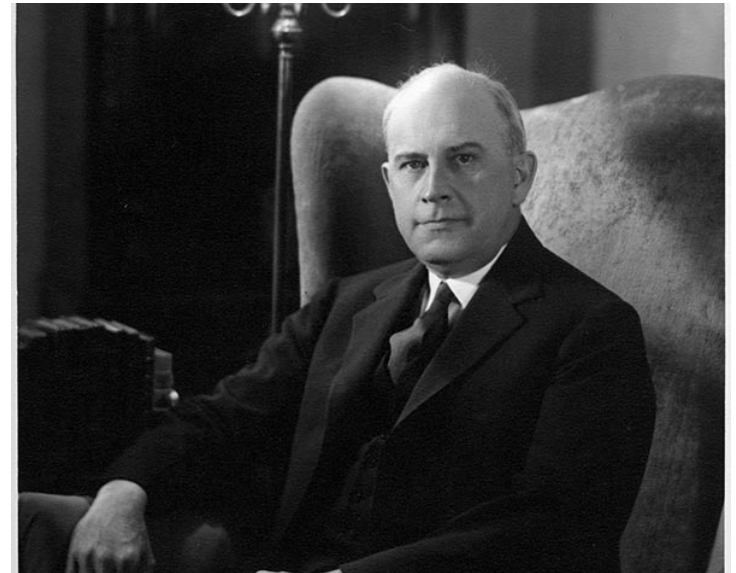

Hardy Cross

The time has come in many fields to take stock. There is continuous production of analytical tools, continuous accumulation of data from tests, continuous construction of bigger and supposedly better machines and structures. But we need now to take stock of what we know, what we do not know, what we need to know and why. There must be more of this work in the future. It is difficult to do at all and very difficult to do well. The sympathetic interest of the research man and the scholar is needed. It must be done in the interest of education on the one hand and of practice on the other; it is wrong to continue indefinitely to add, add, add to the tools of knowledge, without combination or elimination.

